

C
C
C

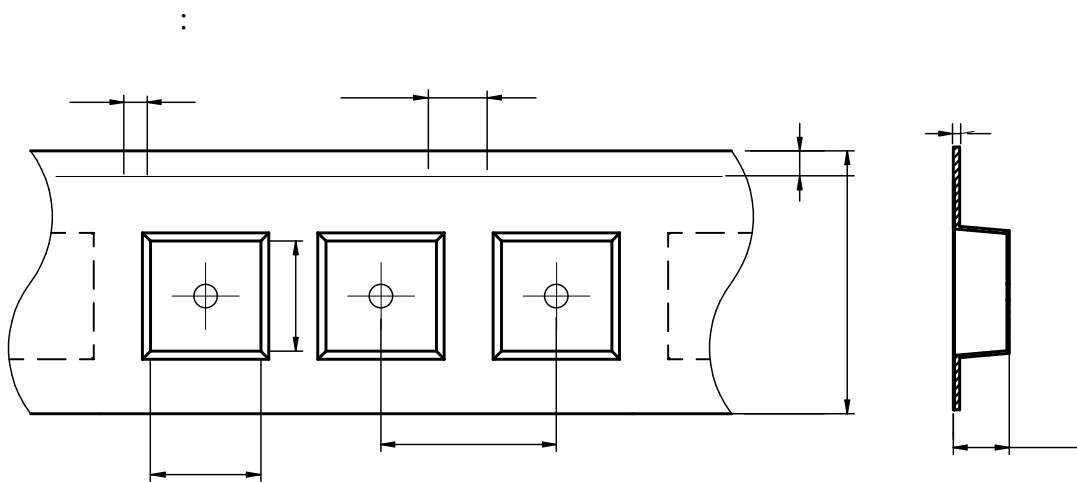

MDTE6030	7.0± 0.1	6.8± 0.1	1.5± 0.1	4.0± 0.1	12.0± 0.1	16.0± 0.3	3.3± 0.1	1.75± 0.1	0.35± 0.05
----------	----------	----------	----------	----------	-----------	-----------	----------	-----------	------------

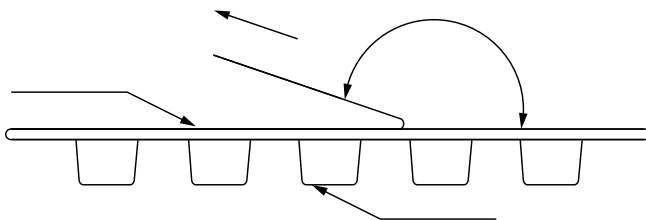

The peel force of top cover tape shall be between 0.1 to 1.3 N

Marking	Printing Inductance)
---------	----------------------

